

MODELS SP2705X7, SP2707X10/2, SP2710X15/2, SP2715X20/2

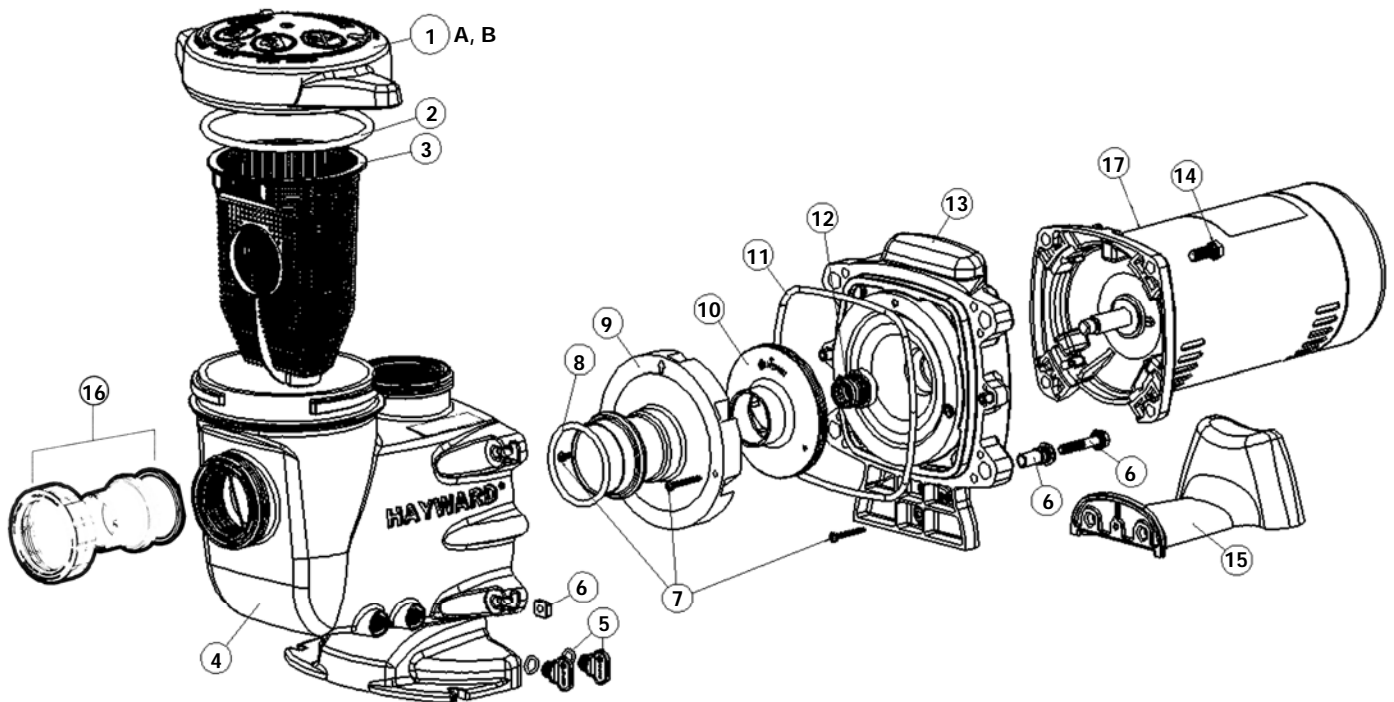

KEY	ITEM #	DESCRIPTION	MFG. #
1A	5110-75	STRAINER COVER KIT (INCLUDES STRAINER COVER, LOCK-RING, O-RING)	SPX2700DLS
1B	5110-76	STRAINER COVER KIT FOR BIGUANIDE SANITIZERS (INCLUDES STRAINER COVER, LOCK-RING, O-RING) NOT PRESSURE TESTABLE	SPX2700DLSH
2	5110-77	STRAINER COVER O-RING	SPX2700Z4
3	5110-78	STRAINER BASKET	SPX2700M
4	5110-79	PUMP STRAINER HOUSING, TXT WITH DRAIN PLUGS THREADED STYLE, BASKET AND STRAINER COVER KIT	SPX2700AA
5	5112-008	DRAIN PLUG WITH O-RING	SPX4000FG
6	5110-80	HARDWARE PACK (INCLUDES 4 HOUSING BOLTS, SEAL-PLATE SPACERS & SQUARE NUTS)	SPX2700ZPAK
7	5110-81	DIFFUSER SCREWS (3 PER)	SPX2700Z3
8	4811-46	DIFFUSER O-RING	SX220Z2
9	5110-82	DIFFUSER	SPX2700H
10	5110-86	IMPELLER FOR 3/4 H.P. MAX- RATE PUMP	SPX2700C
10	5110-87	IMPELLER FOR 1 H.P. MAX- RATE PUMP	SPX2700SC
10	5110-88	IMPELLER FOR 1-1/2 H.P. MAX- RATE PUMP	SPX2707C
10	5110-89	IMPELLER FOR 2 H.P. MAX- RATE PUMP	SPX2710C
11	4822-04	HOUSING O-RING	GMX600F
12	3260-105	SHAFT SEAL ASSEMBLY	SPX2700SA
13	5110-84	SEAL PLATE	SPX2700E
14	5112-221	MOTOR BOLT	SPX3200Z5
15	5110-85	MOTOR SUPPORT	SPX2700G
16	5110-70	UNION CONNECTOR KIT	SPX2700UNKIT
17	5230A	1/2 HP MOTOR	
17	5231A	3/4 HP MOTOR	
17	5232A	1 HP MOTOR	
17	5233A	1 1/2 HP MOTOR	
17	5234A	2 HP MOTOR	
17	5235A	2 1/2 HP MOTOR	