

DELUXE MODELS TA-35D, 40D, 50D, 60D, 100D TAGELUS MODELS TA-30, 35, 40, 50, 60

- ➔ PUREX/ TRITON SYSTEMS
- Also Private Labeled for Helder as a TruFlo filter
- Also Private Labeled as Pool Shield brand

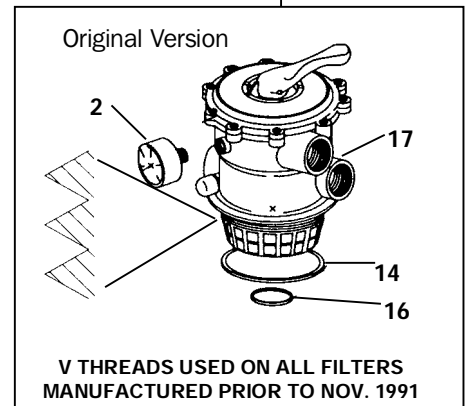
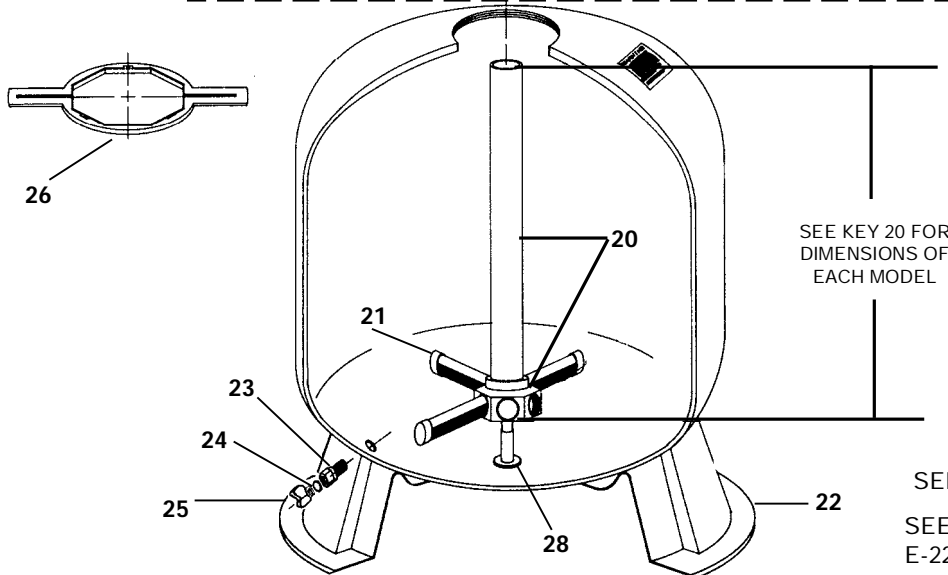
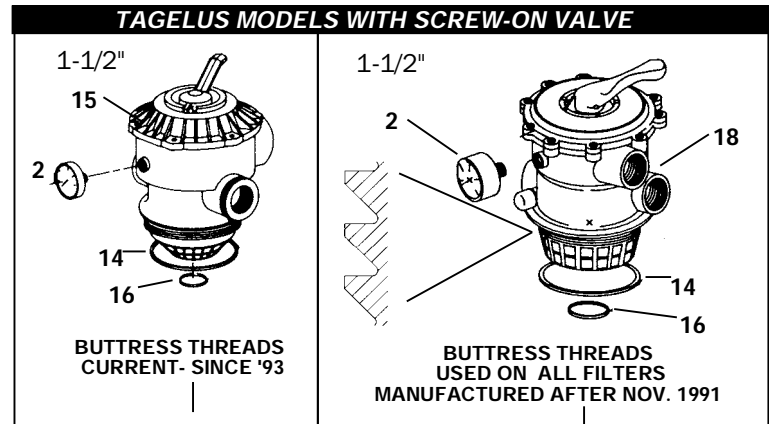
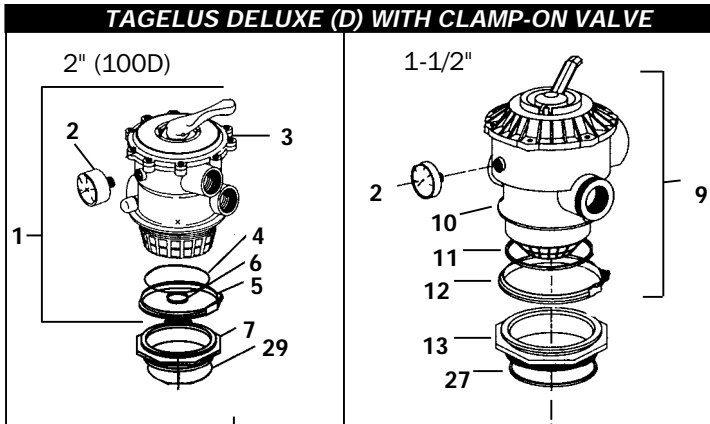
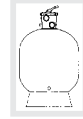

SEE PG D-136 FOR FILTER TO PUMP HOSES
SEE SECTION E PAGES E-21, E-22, & E-24 FOR VALVE PARTS

KEY	ITEM #	DESCRIPTION	MFG. #
	1	4600-1185 VALVE, 2" TOP MT. CLAMP STYLE	261185
	2	4727-1 PRESSURE GAUGE W/ INDICATOR	190059
	3**	4601-1185 VALVE, 2" TOP MOUNT FLANGED-PRAHER	TM22PB
	4	4600-5333 O-RING, VALVE BODY TA100D	275333
	5	4600-2130 CLAMP, VALVE TA 100D ONLY	152130
	6	5002-21 O-RING	355330
	7	4600-4514 ADAPTER, 8 1/2" BUTTRESS THD.	154521
	8	5003-04 O-RING, F/ TA100D	355619
	9	4600-2506 VALVE, 1 1/2" TOP MT. FLANGED	262506
	10**	4601-2506 VALVE, 1 1/2" TOP MT. FLANGED-PRAHER	TM12CFC
	11	4600-2541 O-RING, VALVE BODY TA30D-TA60D	272541
	12	REPLACE NLA CLAMP REP W/4600-2162	155526
	13	4600-4555 ADAPTER, FLANGE BUTTRESS THD. - 6"	154555
	13	4600-5225 ADAPTER, FLANGE V THREAD	155225
	14	4600-4495 O-RING	154493
	15	4600-1130 VALVE, TA-BUTTRESS THD. 1 1/2"	261130
	16	4600-5064 O-RING, STANDPIPE, (NOT USED SINCE '93 ON SCREW THREADED VALVES AND WAS NEVER USED ON ANY VALVES THAT USE A CLAMP)	155064
	17**	4706P VALVE, TOP/MT "V" THRD - PRAHER ORIGINAL VERSION	261124
	18**	4707P VALVE, TOP MT. BUTRS. THD. - PRAHER	261120
	20	4600-5060 PIPING ASSY TA30/30D (12 7/8")	155060
	20	4600-3455 PIPING ASSY TA35/35D (14 7/8")	153455
	20	4600-5061 PIPING ASSY TA40/40D (17 3/4")	155061

KEY	ITEM #	DESCRIPTION	MFG. #
	20	4600-5062 PIPING ASSY TA50/50D (19 7/8")	155062
	20	4600-5063 PIPING ASSY TA60/60D (22 5/8") PRIOR TO 6-07	155063
	20	4600-5299 PIPING ASSY TA60D AFTER 6-07	155299
	20	4600-5323 PIPING ASSY TA100D (27 1/4")	155323
	21	4600-5007 LATERAL, (TA-30, 35, 35D) 5 3/8", 8 REQ	155007
	21	4600-2290 LATERAL, (TA-40, 50, 60D) 6 5/8", 8 REQ	152290
	21	4600-0085 LATERAL, 1/4 TURN TA60D, 6 REQ AFTER 6-07	150085
	21	4600-2202 LATERAL, 9 1/8" (TA-100D), 8 REQ	152202
	22	4600-4596 FILTER BASE (TANK FOOT) TA100/D	154596
	22	4600-4926 FILTER BASE (TANK FOOT) ALL TAGELUS EXCEPT TA100/D	154926
	23	4600-4698 DRAIN ASSEMBLY 3/4" MPT	154698
	23	4600-4685 DRAIN ASSEMBLY 1/2" MPT	154685
	23*	4600-2220 DRAIN ASSY 2" NPT TA100/D	152220
	24	3262-08 O-RING, 1/4" DRAIN PLUG	192115
	24	4600-4492 O-RING FOR TA100/D DRAIN	154492
	25	4600-4699 PLUG, DRAIN 1/4"	154699
	25	4600-4871 DRAIN CAP FOR TA100/D DRAIN	154871
	26	4600-4512 WRENCH, F/ 1 1/2" ADAPTER-KEY 13	154512
	26	4600-1608 WRENCH, F/ 2" ADAPTER-KEY 7	151608
	27	4610-37 O-RING	154494
	28	4601-5002 CENTER PIPE STABILIZER	155002
	29	5003-04 O-RING TA100D	355619

* NOT SHOWN
** VALVE IS A REPLACEMENT BY PRAHER