

KEY ITEM #	DESCRIPTION	MFG. #
1*	4802-01CP VALVE, TOP MOUNT FLANGED-PRAHER	TM12H8
1	4802-01C VALVE, TOP MOUNT FLANGED 1 1/2"	SPO714T
2	4726-0 GAUGE, PRESSURE 0-60 1/4" NPT	ECX270861
3	4822-04 O-RING	GMX600F
4	4802-03D CLAMP, FLANGE - NORYL	GMX600NM
5	OBSOLETE OBSOLETE CAP	SX200Z10
6	4802-04C LATERAL ASSEMBLY WITH PIPE (S-180T)	SX180DA
6	4802-04D LATERAL ASSEMBLY WITH PIPE (S-210T)	SX210DA
6	4802-04E LATERAL ASSEMBLY WITH PIPE (S-220T)	SX220DA
6	4800-65 LATERAL ASSEMBLY WITH PIPE (S-230T)	SX230DA
6	4802-04F LATERAL ASSY WITH PIPE (S-244T & S-270T)	SX244DA
7	4802-72 FILTER TANK (S-180T)	SX180AAZ
7	4802-72A FILTER TANK (S-210T)	SX210AA1
7	4802-72B FILTER TANK (S-220T)	SX220AA1
7	4802-721 FILTER TANK (S-230T)	SX230AA1
7	4802-72C FILTER TANK (S-244T)	SX244AA1
7	4802-722 FILTER TANK (S-270T)	SX270AA1
8	4800-15 LATERAL OLD THREADED STYLE	SX200Q
8	4800-30 LATERAL NEW PIVOT STYLE	SX200QN
8	4800-15A LATERAL OLD THREADED STYLE	SX240D
8	4800-31 LATERAL NEW PIVOT STYLE	SX240DN
9	4802-08 GASKET, DRAIN CAP	SX180G
10	4802-09B DRAIN CAP & GASKET 2005 & PRIOR	SX180HG
11	4800-19 STAND, FILTER SUPPORT	SX200-J
12	4802-16 DRAIN CAP ASSY AFTER 2005	SPX180LA

* REPLACEMENT VALVE BY PRAHER

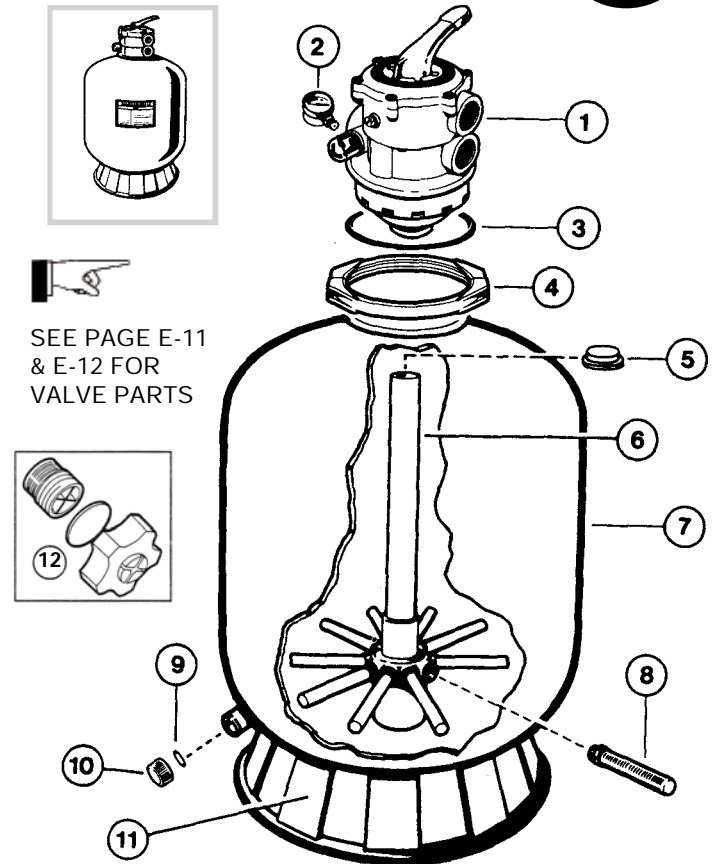

HAYWARD PRO TOP MOUNT 27" & 31"

POLYMERIC SAND FILTER S-310T, S-310T2, S-270T2

KEY ITEM #	DESCRIPTION	MFG. #
1	4802-01C VALVE, TOP MOUNT FLANGED 1 1/2"-HAY	SP0714T
1	4802-01E VALVE, VARI-FLO ASSEMBLY 2"	SP071621
1	4802-02 VALVE, TOP MOUNT 2" WITH CLAMP	SP071620T
2	4726-0 GAUGE, PRESSURE 0-60 1/4" NPT	ECX270861
3	4822-04 O-RING	GMX600F
4	4802-03C CLAMP, FLANGE	SX310N
5	OBSOLETE OBSOLETE CAP	SX200Z10
6	4802-723 FILTER TANK W/SKIRT, DRAIN AND LATERAL ASSY (S270T2)	SX270AA2
6	4802-72D FILTER TANK W/SKIRT, DRAIN AND LATERAL ASSY (S310T & T2)	SX310AA1
7	OBSOLETE OBSOLETE LATERAL ASSY (S270T2)	SX244DA2
7	REPLACE NLA LATERAL PIPE ASSY REP W/4802-14	SX310DA
7	4802-14 LATERAL ASSY., W/ CENTER PIPE (SHORT- CURRENT S310T & T2)	SX310DA2
8	4802-05C LATERAL, (S-310T)	SX310HA
8	OBSOLETE OBSOLETE LATERAL, (S-300T)	SX300HA
8	4800-31 LATERAL (ONE PIECE PIVOT) (S270T2)	SX240DN
8	4800-32 LATERAL (ONE PIECE PIVOT) (S310T & T2)	SX310HN
9	4802-08 GASKET DRAIN CAP	SX180G
10	REPLACE NLA CAP & GASKET KIT REP W/ 4802-09B	SX180H
11	4800-19 STAND, FILTER (IVORY COLOR) PRIOR TO 91	SX200J
11	4802-33 STAND, FILTER (TAUPE COLOR) CURRENT	SX310J
12	4802-16 DRAIN CAP ASSY AFTER 2005	SPX180LA
*	4802-24 DIFFUSER (S-300T) PRIOR TO 88	SX300E

* NOT SHOWN

